

Installation and Maintenance Manual

HyperSpike® LineWave

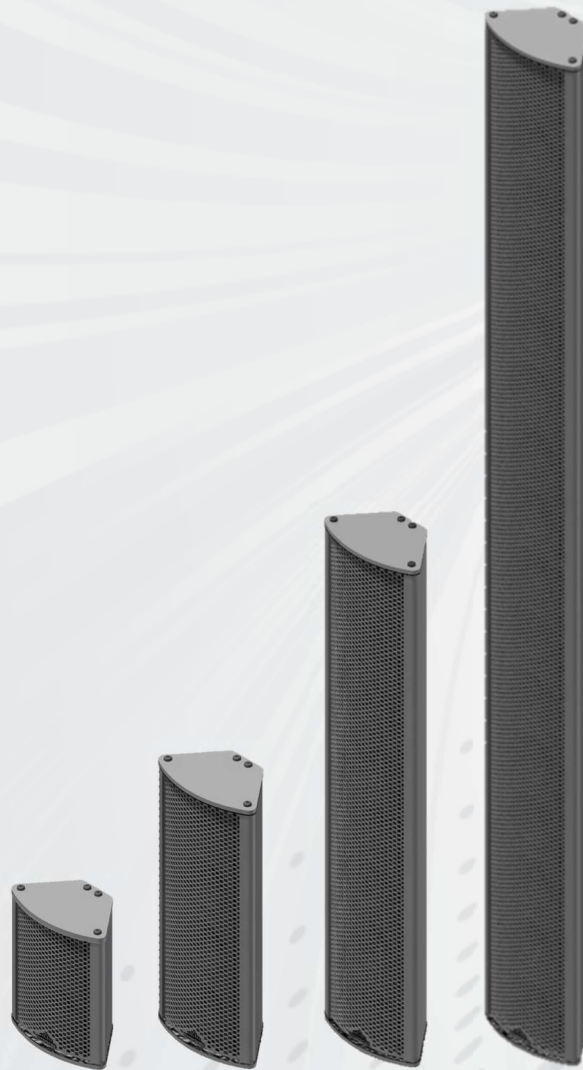

ISSUE DATE: 12/16/2019

ORIGINAL ISSUE DATE RELATED TO MOUNTING AND WIRING DIAGRAM ONLY.
CHANGE TO ISSUE DATE WILL AFFECT RELATED LABELS

-----WARNING-----
EXPORT, RE-EXPORT, AND TRANSFER OF THIS TECHNICAL DATA IS REGULATED BY US EXPORT ADMINISTRATION
REGULATIONS AND MAY BE SUBJECT TO LICENSING REQUIREMENTS FROM THE BUREAU OF INDUSTRY AND SECURITY.

Contents

1. Introduction.....	1
1.1. Part Number Breakdown:.....	1
1.2. LineWave Specifications.....	3
1.3. Line Wave UL Directional Characteristics.....	4
1.4. LineWave Transformer Specifications.....	4
2. Installation.....	4
2.1. 4Ω, 8Ω, and 16Ω System Overview.....	5
2.2. Distributed Audio System Overview.....	5
2.3. 25V/70V/100V Transformer – Recommended Hole Locations and Alignment.....	6
2.4. 72542B-80X Circuit Breaker Reset.....	7
2.5. Wall Mounting.....	8
2.6. 72544B-802 – Wall Mounting Kit Installation:.....	9
2.7. 72544B-801 – Wall Mounting Kit Installation:.....	10
2.8. Pole Mounting.....	15
3. 25V/70V/100V Power and SPL Specifications.....	17
3.1. 72575B-801 - Power Draw and Output SPL.....	17
3.2. 72575B-801 Transformer Wiring Guide – Used for 90243A-801 and 90243A-802.....	18
3.3. 72542B-801 - Power Draw and Output SPL.....	19
3.4. 72542B-801 Transformer Wiring Guide – Used for 90243A-803.....	19
3.5. 72542B-802 - Power Draw and Output SPL.....	20
3.6. 72542B-802 Transformer Wiring Guide – Used for 90243A-804.....	20
4. Warranty.....	21

 **CAUTION: EXCEEDING THE MAXIMUM RATINGS OF THE SPEAKER WILL CAUSE EXCESSIVE DISTORTION AND MAY CAUSE PERMANENT DAMAGE TO THE SPEAKER AND ITS INTERNAL COMPONENTS.**

 **MISE EN GARDE: TOUT DÉPASSEMENT DES VALEURS NOMINALES MAXIMALES DU HAUT-PARLEUR ENTRAÎNERA UNE DISTORSION EXCESSIVE ET PEUT PROVOQUER DES DOMMAGES IRRÉVERSIBLES SUR LE HAUT-PARLEUR ET SES COMPOSANTS INTERNES.**

 **WARNING: EXPLOSION HAZARD. DO NOT DISCONNECT THE EQUIPMENT UNLESS POWER HAS BEEN SWITCHED OFF OR UNLESS THE AREA IS KNOWN TO BE NON-HAZARDOUS.**

 **AVERTISSEMENT : RISQUE D'EXPLOSION. NE DÉBRANCHEZ PAS L'ÉQUIPEMENT AVANT DE L'AVOIR MIS HORS TENSION OU SAUF SI LA ZONE EST CONNUE POUR ÊTRE NON DANGEREUSE.**

 **WARNING: WHEN MOUNTING OUTSIDE MAKE SURE THAT THE SUPPORT SYSTEM USED HAS THE PROPER WIND LOAD RATING AND COMPLIES WITH LOCAL STANDARDS AND CODES.**

 **AVERTISSEMENT : EN CAS DE MONTAGE EXTERNE, ASSUREZ-VOUS QUE LE SYSTÈME DE SUPPORT UTILISÉ A UNE CHARGE DE VENT NOMINALE APPROPRIÉE ET QU'IL EST CONFORME AUX NORMES ET CODES LOCAUX.**

 **WARNING: DO NOT CHANGE FACTORY-APPLIED FINISH**

 **AVERTISSEMENT : NE MODIFIEZ PAS LA FINITION APPLIQUÉE EN USINE**

1. Introduction

Designed with the latest technology in line array speaker systems, the HyperSpike® LineWave is optimized to produce clear and authoritative voice commands and powerful tones never before possible within reverberant environments. The beam forming capability of the LineWave speaker allows even coverage across the listening plane while focusing the acoustic pattern away from surfaces that cause unwanted reflections. This technology is essential for achieving optimum levels of speech intelligibility within reverberant spaces. The result is clear and intelligible direct sound that ensures critical messages are heard and understood.

The LineWave is ready to be installed in either indoor or outdoor applications, and can be configured to operate in 25V, 70V, or 100V distributed audio or 16, 8, or 4 Ohm direct drive applications. Available in four different sizes, the LineWave offers exceptional scaling capabilities for any size installation.

1.1. Part Number Breakdown:

The LineWave is available with either 2, 4, 8, or 16 speakers and is offered in several color options. The following breakdown describes the model number configurations:

90243A-80X-XX-L

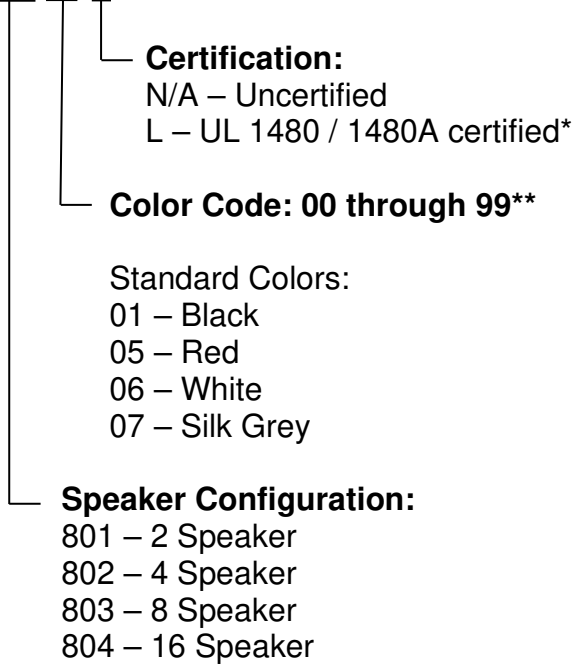

* Note: The LineWave speaker is UL 1480A certified when powered as a direct drive unit. When powered with accessory transformer 72575B-80X or 72542B-80X the unit is UL 1480 certified.

** Note: Color Codes not listed as Standard Colors are custom. Cost and lead time provided per customer request.

1.2. LineWave Specifications

System	90243A-801	90243A-802	90243A-803	90243A-804
Type	Full Range, Column Loudspeaker			
Operation Mode	16/8/4Ω Loudspeaker with Optional Line Matching Transformer			
Number of Speakers in Array	2	4	8	16
Maximum Power Draw: 16Ω, 8Ω, and 4Ω Models	20W	40W	80W	160W
Max SPL @ 1m, 18V Direct Drive	105dB	111dB	117dB	123dB
Peak SPL @ 1m	113dB	119dB	125dB	131dB
Usable Range @ 80dB, A-Weighted	17m (56ft)	35m (115ft)	70m (230ft)	141m (463ft)
*Reverb SPL @ 10 ft, 18V Direct Drive	87.8	91.7	94.3	95.7
*Anechoic SPL @ 3m, 18V Direct Drive	93.4	98.0	103.0	104.0
Input Sensitivity (2.83Vrms/1m)	85dB	91dB	97dB	103dB
Nominal Impedance	16Ω	8Ω	4Ω	4Ω, 2 Channel
Vertical Coverage -9dB (Avg. 1kHz-4kHz)	99°	45°	21°	10°
Frequency Response (+/- 6dB)	250Hz-15kHz			
Required Input Signal Processing	High Pass at 200Hz – Direct Drive Models Only			
Horizontal Coverage -9dB (Avg. 1kHz-4kHz)	187°			
Maximum Input Voltage: 16Ω, 8Ω, and 4Ω Models	18V RMS, 36V Peak			
Standard Colors**	(01) Black, (05) Red, (06) White, (07) Silk Grey			
Enclosure Material	Aluminum			
Grille Material	Steel			
Input Connection	SJOOW Cable, 6ft. Provided			
Ingress Protection	Indoor and Outdoor Applications			
Product Dimensions, HxWxD (in)	6.6 x 4.9 x 2.9	12.3 x 4.9 x 2.9	23.7 x 4.9 x 2.9	46.5 x 4.9 x 2.9
Net Weight (lbs)	2.6	4.3	7.5	14.7

*UL Standard SPL Measurement

** Note: Color Codes not listed as Standard Colors are custom. Cost and lead time provided per customer request.

1.3. Line Wave UL Directional Characteristics

		90243A-801	90243A-802	90243A-803	90243A-804
HORIZONTAL AXIS	-3Db Angle	+/- 35°	+/- 40°	+/- 40°	+/- 40°
	-6Db Angle	+/- 65°	+/- 70°	+/- 70°	+/- 75°
	SPL @ +/- 90°	86.2 dBA	90.8 dBA	95.2 dBA	98.2 dBA
VERTICAL AXIS	-3Db Angle	+/- 35°	+/- 20°	+/- 10°	+/- 10°
	-6Db Angle	+/- 65°	+/- 45°	+/- 25°	+/- 20°
	SPL @ +/- 90°	86.2 dBA	88.2 dBA	89.3 dBA	88.3 dBA

1.4. LineWave Transformer Specifications

System	72575B-801	72542B-801	72542B-802
Type	Optional Transformer		
Operation Mode	25 / 70 /100 Watt Tap Settings		
Line Wave Compatibility	90243A-801/802	90243A-803	90243A-804
Maximum Power Draw:	30W	85W	170W
Maximum Supervisory Voltage: 25V/70V/100V Models	32V DC		
Enclosure Material	Plastic		
Ingress Protection	Indoor/Outdoor		
Product Dimensions, HxWxD (in)	5.9 x 5.9 x 3.9	9.8 x 5.9 x 3.9	9.8 x 5.9 x 3.9
Net Weight	3lbs	4.5lbs	6.5lbs

2. Installation

LineWave speakers are by default configured as 4Ω, 8Ω, or 16Ω loudspeakers, however, an optional line matching transformer is available if it is desired to connect the LineWave to a Distributed Audio system. LineWave loudspeakers are approved for use with 25V, 70V, and 100V amplifiers. When configured for 25V, 70V, or 100V input, the LineWave includes a DC blocking capacitor to facilitate DC speaker supervision.

All LineWave systems utilize an outdoor rated SJOOW cable for electrical connections. To connect your LineWave speaker to an amplifier, route the cable to an appropriate junction box, or other connector, as approved by local electrical codes and standards. For ease of installation into a junction box, a Strain-Relief Cord Connector is included.

Note: In the United States reference National Electrical Code (NFPA 70) and National Fire Alarm and Signaling Code (NFPA 72) for installation standards.

Note: In Canada reference CSA C22.1, Canadian Electrical Code, Part 1, Safety Standard for Electrical Installations, Section 32, for installation standards.

2.1. 4Ω, 8Ω, and 16Ω System Overview

LineWave Models 90243A-801, 90243-802, and 90243A-803 (16Ω, 8Ω, and 4Ω respectively) provide a six foot SJOOW-18/2 cable for amplifier interconnection. Refer to the images in this section for polarity information.

LineWave Model 90243A-804 provides a six foot SJOOW-18/4 cable wired as two 4Ω channels for amplifier interconnection. If your amplifier is capable of driving a 2Ω load, these channels may be tied in parallel on a single amplifier channel. Refer to the images in this section for polarity information.

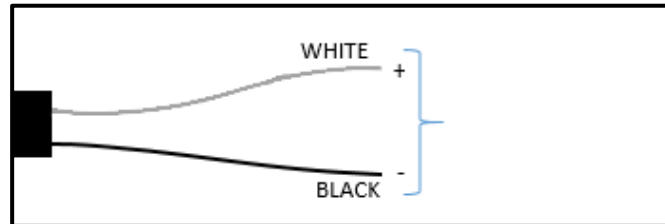

Figure 1. Wiring Diagram - 90243A-801, 90243-802, and 90243A-803

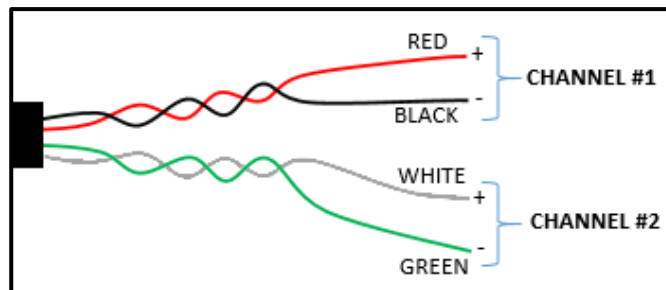

Figure 2. Wiring Diagram - 90243A-804

2.2. Distributed Audio System Overview

An optional 25V/70V/100V transformer allows the LineWave to be connected to 25V, 70V, or 100V distributed audio networks. It has four field-selectable power taps on the provided terminal block that allow the output SPL to be tuned to specific applications. The 25V/70V/100V transformer assembly also has an integrated DC blocking capacitor that allows amplifiers to conduct DC circuit supervision. The taps can be selected by wiring 25/70/100V input lines to the appropriate terminal block contacts, as shown in the wiring diagrams included in this section. Once the system is mounted, reference Section 3 for tables detailing the power draw and output SPL of LineWave speakers when using the available transformer tap settings.

Note: Section 1.2 lists the 25V/70V/100V transformers which are available for each model of LineWave loudspeaker.

Note: Terminal Block is rated for 22-14AWG wire

2.3. 25V/70V/100V Transformer – Recommended Hole Locations and Alignment

In order to connect the LineWave's SJOOW cable to the transformer assembly, utilize the included Strain-Relief Cord Connector. This connector requires a 0.740" hole to be drilled in the transformer assembly. Consult the following recommended hole locations before drilling.

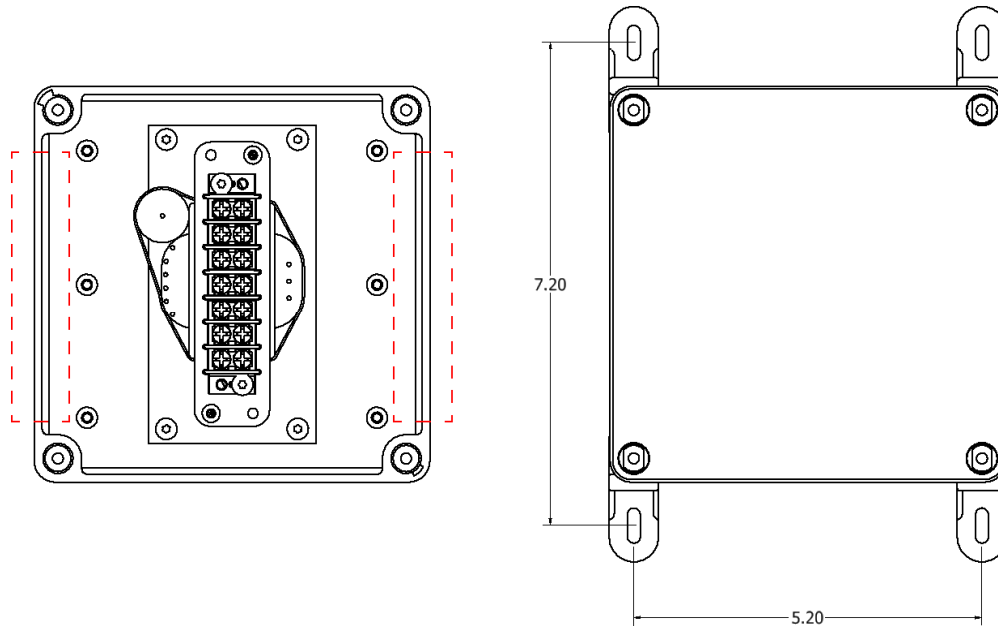

Figure 3. 72575B-801 Recommended Hole Locations, shown in red dashed boxes

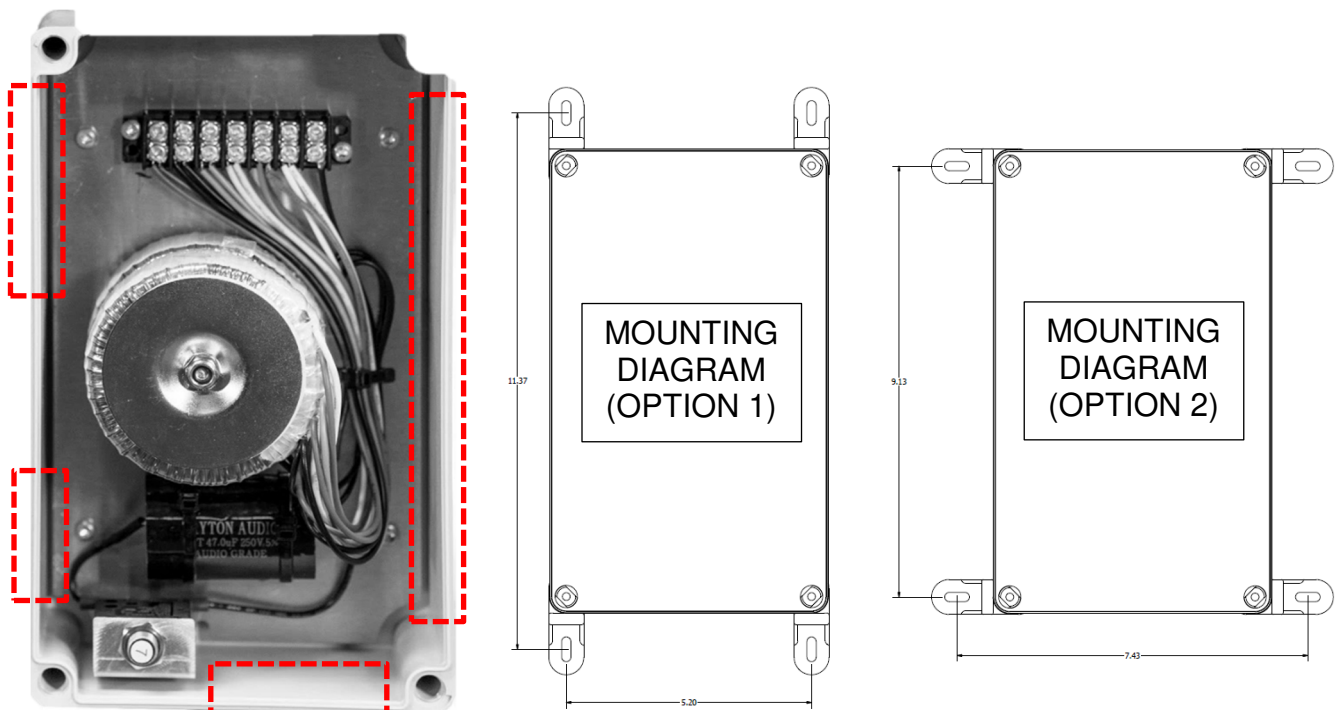

Figure 4. 72542B-801 and 72542B-802 Recommended Hole Locations, shown in red dashed boxes

The orientation of the transformer cover is important to maintaining a water tight seal. Refer to Figure 5 to confirm alignment before replacing the transformer cover.

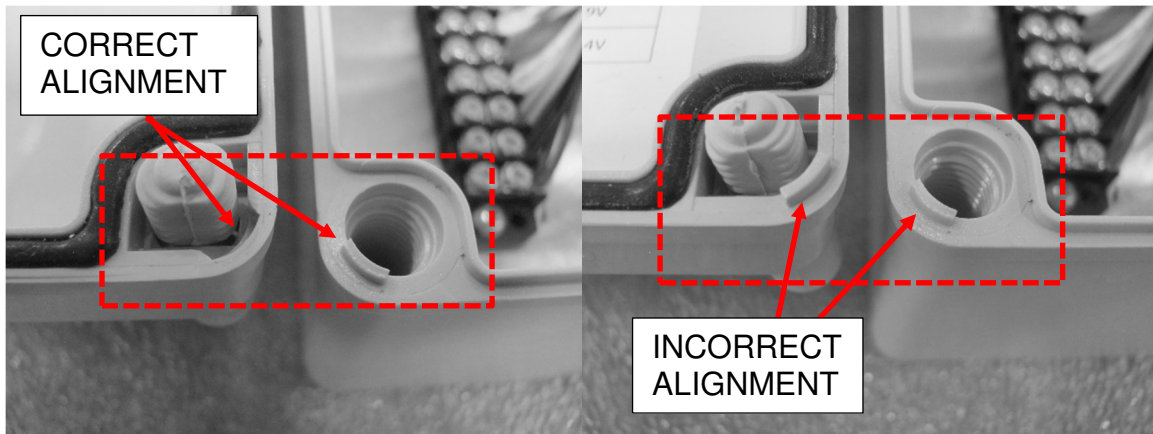

Figure 5. Transformer Lid Orientation

2.4.72542B-80X Circuit Breaker Reset

Transformer 72542B-80X has an integrated circuit breaker that protects itself from line surges and short circuits. The circuit breaker is located inside the transformer housing near the capacitor. If the breaker would trip, follow the steps below:

1. Remove the transformer housing lid.
2. Push to reset the breaker (the button on the breaker should push in and stay).
3. Install the transformer housing lid.

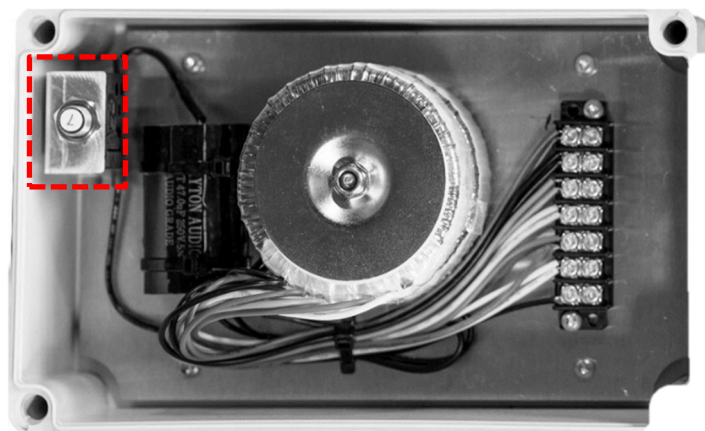

Figure 6. Circuit Breaker Reset

2.5. Wall Mounting

Hardware intended to mount LineWave loudspeakers to a wall surface is included with every purchase.

System	90243A-801	90243A-802	90243A-803	90243A-804
Number of Speakers in Array	2	4	8	16
Model Number of Included Wall Mounting Kit	72544B-802	72544B-802	72544B-801	72544B-801

The following tables list the hardware included in the 72544B-801 and 72544B-802 wall mounting kits.

72544B-801 Wall Mounting Kit

PART	DESCRIPTION	QUANTITY
A	PIVOT NUB	3
B	L BRACKET	2
C	TIE BAR	2
D	1/4" WASHER	6
E	1/4"-20 x 1-5/8" SCREW	2
F	1/4"-20 LOCK NUT	3
G	1/4"-20 x 5/8" SCREW	1
H	1/4"-20 T NUT	4
J	1/4"-20 x 1" SCREW	4
K	1/4"-20 x 1" SET SCREW	1

72544B-802 Wall Mounting Kit

PART	DESCRIPTION	QUANTITY
A	PIVOT NUB	1
B	L BRACKET	1
D	1/4" WASHER	1
G	1/4"-20 x 5/8" SCREW	1
H	1/4"-20 T NUT	2
J	1/4"-20 x 1" SCREW	2

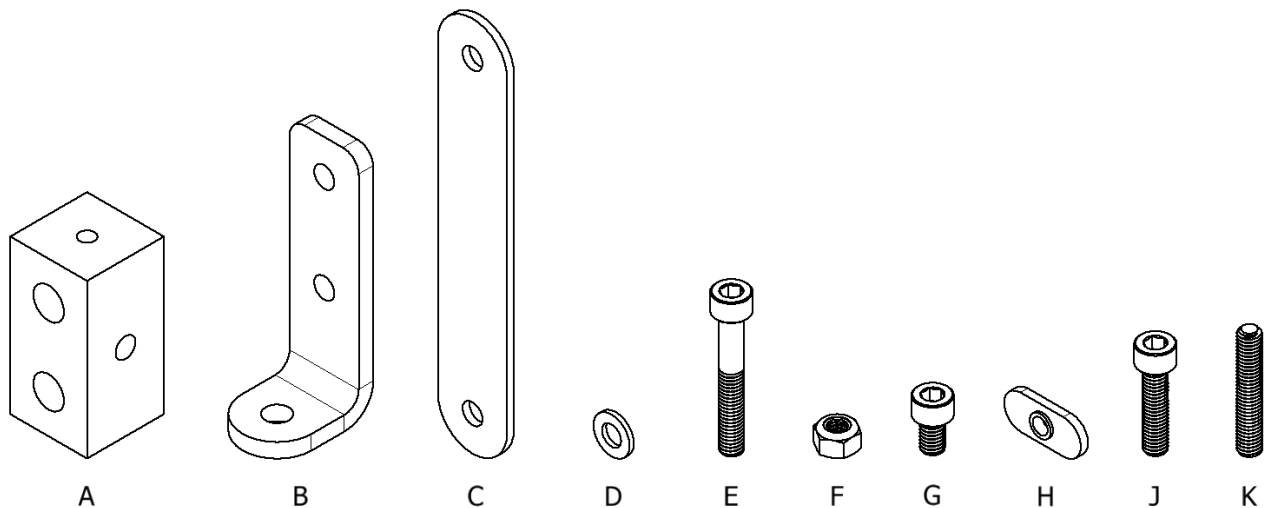

2.6. 72544B-802 – Wall Mounting Kit Installation:

Reference the following instructions to install a LineWave 90243A-801 or 90243A-802 on a wall surface:

1. Fasten L Bracket (Part B) to the wall surface using appropriate fasteners for the wall, according to local codes and safety practices. *Wall fasteners are not included in the mounting kit.*
2. Insert two T-Nuts (Part H) into the slot on the back of the LineWave and attach Pivot Nub (Part A) using two 1" long screws (Part J).
3. Mount the LineWave by connecting Pivot Nub to L Bracket using flat washer (Part D) and 5/8 long screw (Part G).
4. To aim the speaker left or right, loosen the 5/8 long screw (Part G) and pivot the unit to the desired position. Once the speaker is in the appropriate position, re-tighten screw.

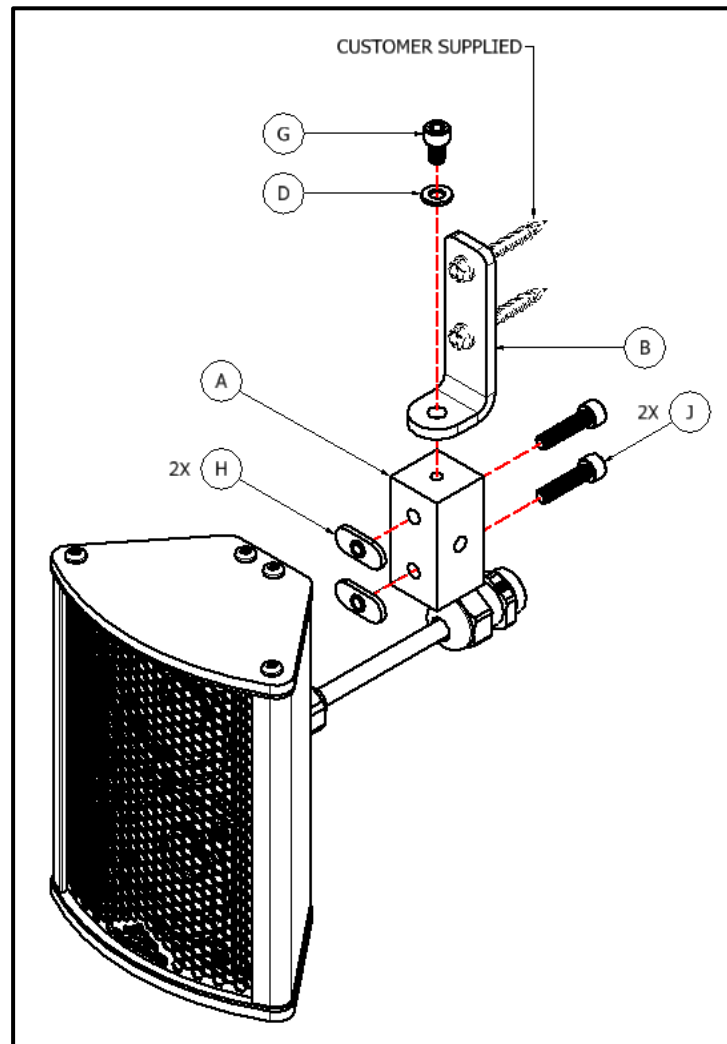

Figure 7. 90243A-801 and 90243A-802 Wall Mounting

2.7. 72544B-801 – Wall Mounting Kit Installation:

Reference the following instructions to install a LineWave 90243A-801 or 90243A-802 on a wall surface:

1. Fasten two L Brackets (Part B) to the wall surface using appropriate fasteners for the wall. Always follow local codes and safety practices. *Wall fasteners are not included in the mounting kit.*
 - a. 90243A-803 - L Bracket recommended spacing is 20" apart.
 - b. 90243A-804 - L Bracket recommended spacing is 43" apart.

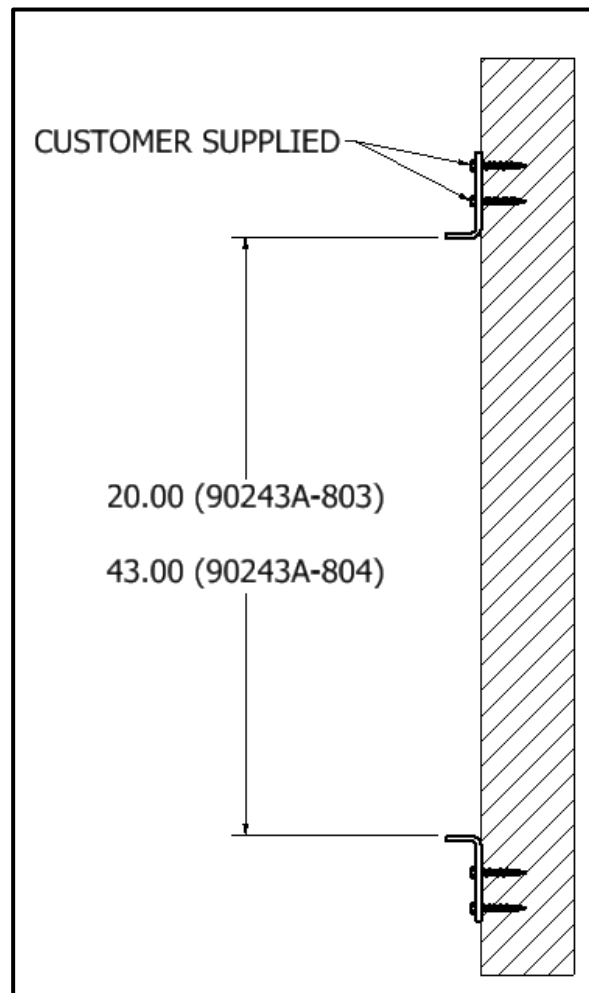

Figure 8. 90243A-803 and 90243A-804 Wall Mounting – Step 1

2. Attach two Tie Bars (Part C) to Pivot Nub (Part A) using two flat washers (Part D), 1-5/8" long screw (Part E), and lock nut (Part F) as shown in Figure 9.

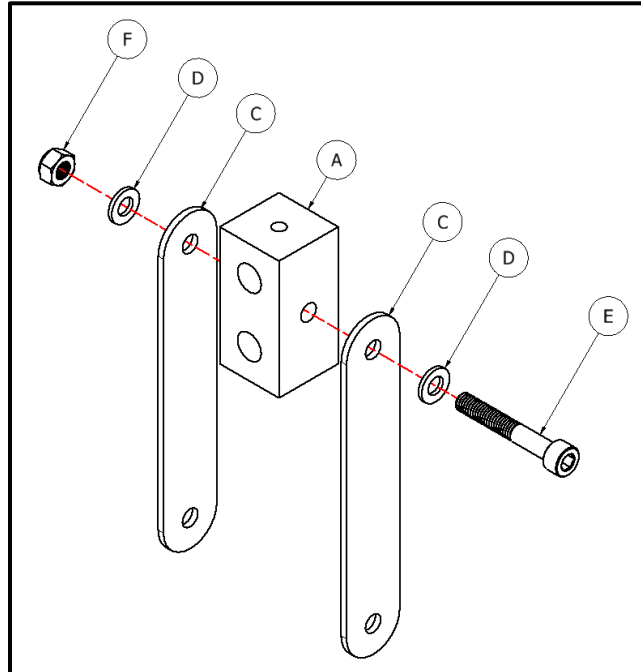

Figure 9. 90243A-803 and 90243A-804 Wall Mounting – Step 2

3. Attach Pivot Nub Assembly from Step 2 to the top L-Bracket using flat washer (Part D) and 5/8 long screw (Part G).

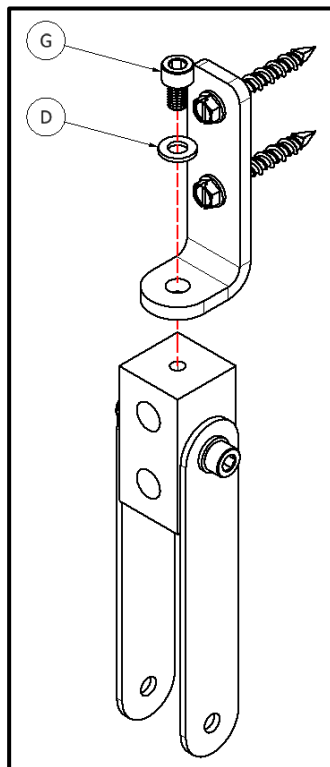

Figure 10. 90243A-803 and 90243A-804 Wall Mounting – Step 3

4. Insert four T-Nuts (Part H) into the slot on the back of the LineWave and attach two Pivot Nubs (Part A) 1" from each end, using four 1" long screws (Part J). On the bottom Pivot Nub install set screw (Part K) as shown in [Figure 11](#).

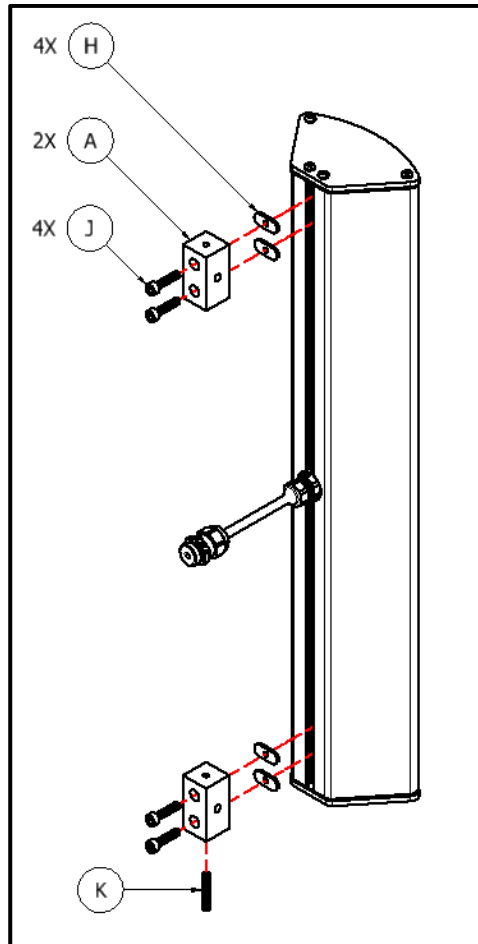

Figure 11. 90243A-803 and 90243A-804 Wall Mounting – Step 4

- Lift the LineWave with Pivot Nubs and insert Set Screw into the hole of the bottom L Bracket. While still holding the LineWave, fasten the top Pivot Nub to the Tie Bars from step 1, using 1-5/8" Long Screw (Part E), two Flat Washers (Part D), and Lock Nut (Part F).

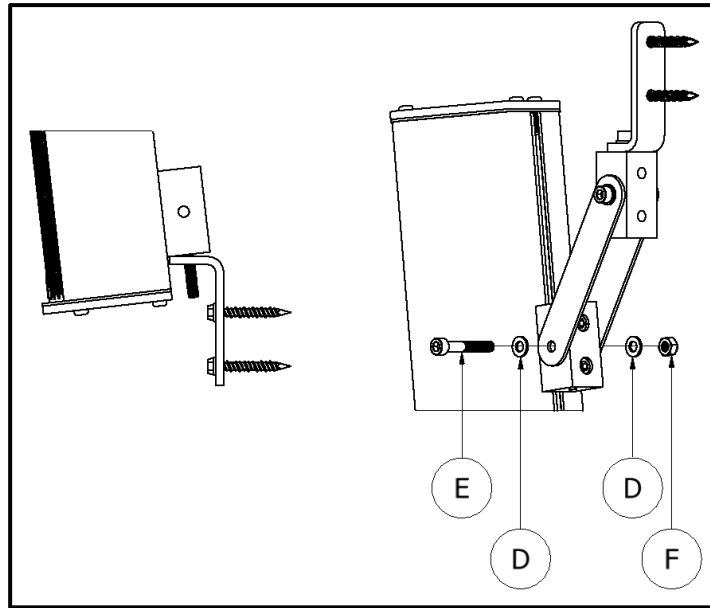

Figure 12. 90243A-803 and 90243A-804 Wall Mounting – Step 5

- To aim the speaker left or right, loosen the top screw and pivot the unit to the desired position as shown in [Figure 13](#). Once the speaker is in the appropriate position, retighten screw. Pan angle is adjustable within +/- 50°.

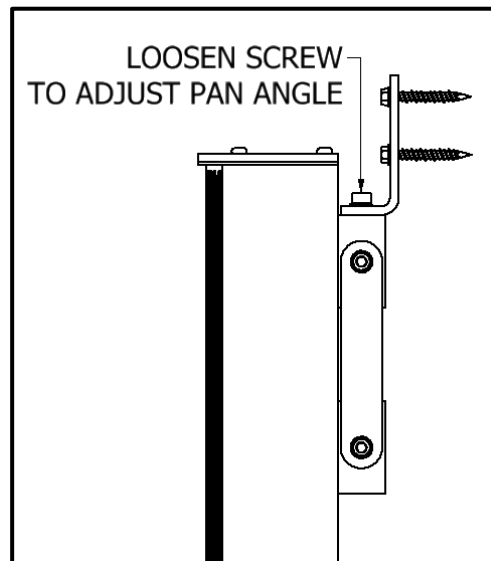

Figure 13. 90243A-803 and 90243A-804 Wall Mounting – Step 6

- To aim the speaker down, loosen (but don't remove) the two bolts fastening the top Pivot Nub to the LineWave. Slide the Pivot Nub up and down to adjust the tilt angle to the desired orientation as shown in [Figure 14](#). The LineWave may need to be temporarily rotated left or right in order to access the screws.

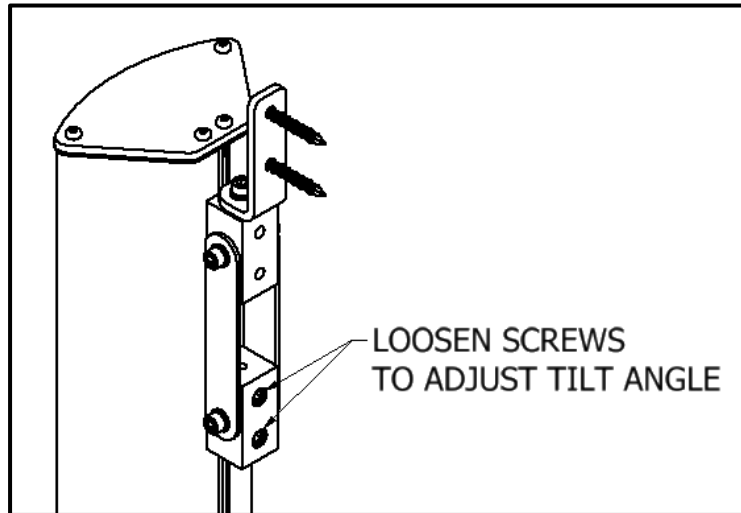

Figure 14. 90243A-803 and 90243A-804 Wall Mounting – Step 7

- Once the desired orientation is achieved, tighten all fasteners. Install flat washer (Part D) and lock nut (Part F) onto bottom set screw.

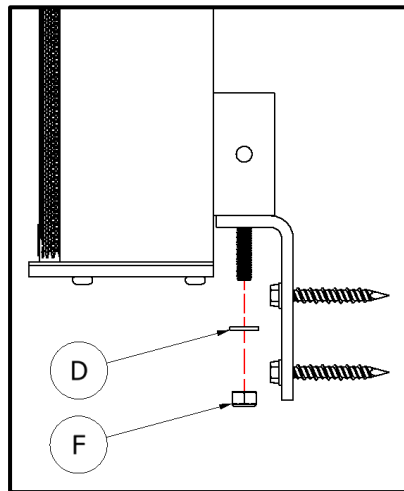

Figure 15. 90243A-803 and 90243A-804 Wall Mounting – Step 8

2.8. Pole Mounting

An optional Pole Mounting Kit (HyperSpike® item number 72581B-801) is available for LineWave models 90243A-803 and 90243A-804, which allows mounting to poles ranging from 3-7" in diameter. This kit is used in conjunction with the wall mounting hardware supplied with the speaker unit.

The following table lists the hardware included in the 72581B-801 Pole Mount Kit.

72581B-801 Pole Mounting Kit

PART	DESCRIPTION	QUANTITY
D	1/4" WASHER	8
F	1/4"-20 LOCK NUT	4
L	POLE MOUNT BRACKET	2
J	1/4"-20 x 1" SCREW	4
M	STRAP	4

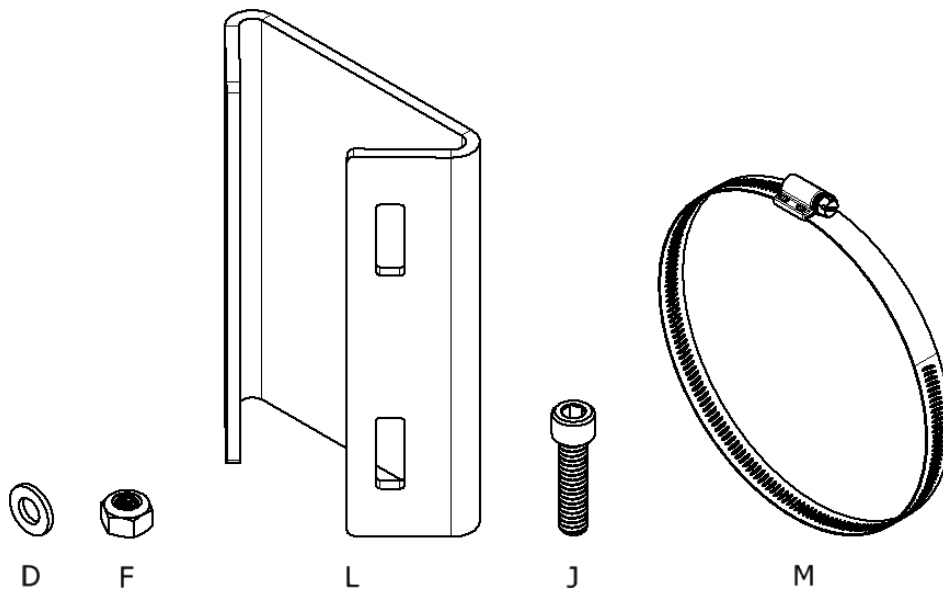

Follow these steps to install a LineWave using the Pole Mounting Kit

1. Fasten L Bracket (Part B) of the wall mount kit to the Pole Mount Bracket (Part L) using two flat washers (Part D), two lock nuts (Part F), and two 1" long screws (Part J). Repeat process with second bracket.

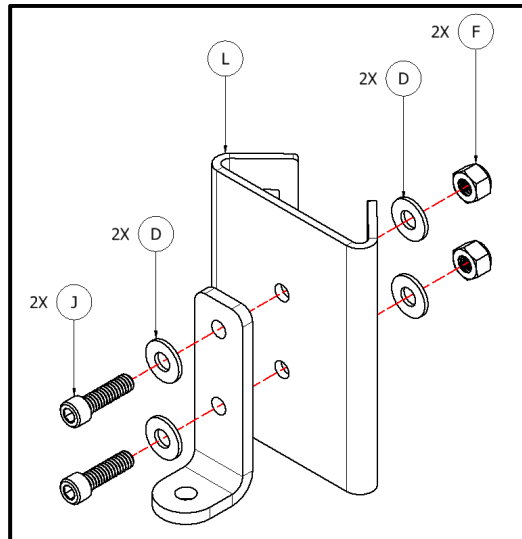

Figure 16. 72581B-801 Pole Mounting – Step 1

2. Fasten the Pole Mount Bracket assembly to pole using straps (Part M).
 - a. 90243A-803 - L Bracket recommended spacing is 20" apart.
 - b. 90243A-804 - L Bracket recommended spacing is 43" apart.

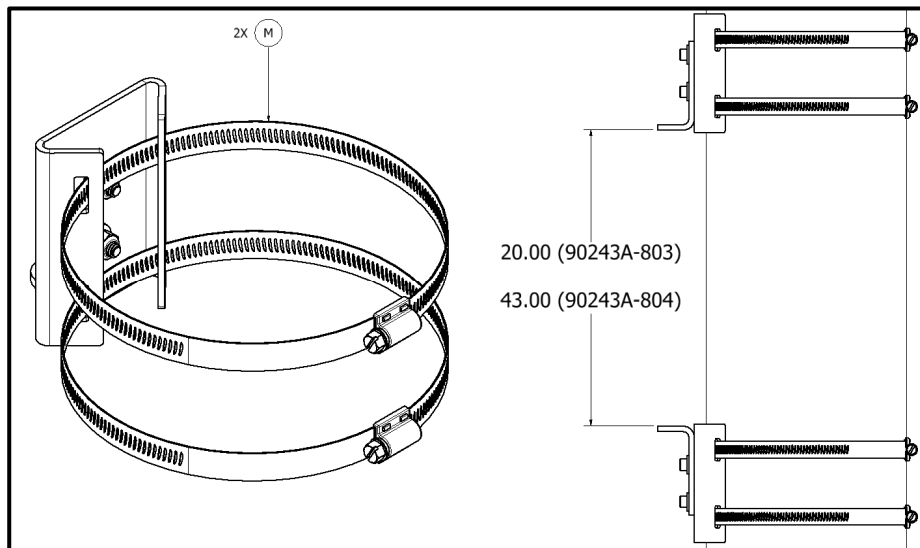

Figure 17. 72581B-801 Pole Mounting – Step 2

3. Proceed with mounting and adjusting the angle of the speaker unit as described in Section 2.6.

3. 25V/70V/100V Power and SPL Specifications

Use the Power Draw and SPL Output tables in this section to select the LineWave model and drive level appropriate for your application. Once a specific tap is selected, reference the included wiring diagrams during installation.

3.1.72575B-801 - Power Draw and Output SPL

Model Number	Input Voltage RMS	Tap Color	Power Draw, Watts	dB SPL Max 1M, A-Weighted	* dB SPL Reverb @ 10ft	* dB SPL Anechoic @ 3m
90243A-801	25V	Blue	0.5	86	72.4	78.2
	25V	Orange	1.3	91	77.1	82.2
	25V	Red	1.6	92	78.2	83.8
	25V	Brown	2.7	94	79.9	85.3
	70V	Blue	3.0	95	80.8	86.3
	70V	Orange	8.3	100	84.9	90.7
	70V	Red	10.7	101	85.9	91.9
	70V	Brown	15.3	103	87.2	92.7
	100V	Blue	5.7	98	83.5	89.1
	100V	Orange	15.3	103	87.1	92.9
	100V	Red	19.5	104	88.0	93.8
90243A-802	25V	Blue	0.8	92	75.8	81.9
	25V	Orange	2.2	97	80.5	86.6
	25V	Red	2.8	98	81.6	87.8
	25V	Brown	4.1	100	83.2	89.4
	70V	Blue	5.3	101	84.4	91.2
	70V	Orange	14.9	106	88.6	94.6
	70V	Red	19.3	107	89.5	95.6
	70V	Brown	27.4	109	90.7	96.9
	100V	Blue	10.3	104	87.1	92.9
	100V	Orange	27.8	109	90.9	96.9

*UL Standard SPL Measurement

3.2.72575B-801 Transformer Wiring Guide – Used for 90243A-801 and 90243A-802

SIGNALING

LISTED

TYPE F SUBASSEMBLY
 S35565
 ISSUE DATE: 12/16/2019

TRANSFORMER MODULE

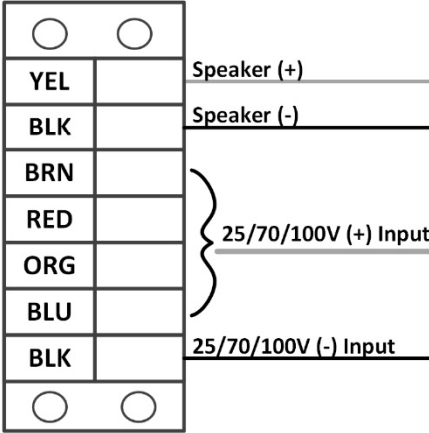
72575B-801-L Low Power Transformer
 Secure Speaker (+), Speaker (-), and Input (-) as shown.
 Secure 25/70/100V (+) Input to desired power setting.
 Table assumes 90243A-801 and 90243A-802 load.



Input Power Requirements			
Input (VRMS)	Tap Color	Power (W) 90243A-801	Power (W) 90243A-802
25	BLU	0.5	0.8
	ORG	1.3	2.2
	RED	1.6	2.8
	BRN	2.7	4.1
70	BLU	3.0	5.3
	ORG	8.3	14.9
	RED	10.7	19.3
	BRN	15.3	27.4
100	BLU	5.7	10.3
	ORG	15.3	27.8
	RED	19.5	DO NOT USE
	BRN	DO NOT USE	DO NOT USE

	UL 1480 Minimum SPL @ 10ft	ULC S541 Minimum SPL @ 3m
90243A-801	72.4	78.2
90243A-802	75.8	81.9

INDOOR AND OUTDOOR DAMP

INSTALLATION INSTRUCTIONS:
 90243A-MAN-LINEWAVE

MAX VOLTAGE:
 100VRMS

MAX SUPERVISORY VOLTAGE:
 32VDC

15225A-1 REV D

3.3.72542B-801 - Power Draw and Output SPL

Model Number	Input Voltage RMS	Tap Color	Power Draw, Watts	dB SPL Max 1M, A-Weighted	* dB SPL Reverb @ 10ft	* dB SPL Anechoic @ 3m
90243A-803	25V	Blue	1.7	101	79.9	87.8
	25V	White	3.3	103	82.9	91.0
	25V	Orange	6.6	105	85.9	94.3
	25V	Yellow	12.7	108	88.5	96.6
	70V	Blue	12.4	110	88.5	96.6
	70V	White	23.9	112	91.2	99.5
	70V	Orange	46.2	114	93.8	102.0
	70V	Yellow	81.6	117	95.8	104.0
	100V	Blue	23.8	113	91.2	99.0
	100V	White	44.6	115	93.6	101.0
	100V	Orange	83.3	117	96.0	104.0

*UL Standard SPL Measurement

3.4.72542B-801 Transformer Wiring Guide – Used for 90243A-803

TRANSFORMER MODULE



SIGNALING
TYPE F SUBASSEMBLY
S35565
ISSUE DATE: 12/16/2019

72542B-801-L High Power Transformer

Secure Speaker (+), Speaker (-), and Input (-) as shown.
Secure 25/70/100V (+) Input to desired power setting.
Table assumes 90243A-803 load.

Input Power Requirements				
Input (VRMS)	Tap Color	Power (W) 90243A-803	UL 1480 SPL @ 10ft 90243A-803	ULC S541 SPL @ 3m 90243A-803
25	BLU	1.7	79.9	87.8
	WHT	3.3	82.9	91.0
	ORG	6.6	85.9	94.3
	YEL	12.7	88.5	96.6
70	BLU	12.4	88.5	96.6
	WHT	23.9	91.2	99.5
	ORG	46.2	93.8	102.0
	YEL	81.6	95.8	104.0
100	BLU	23.8	91.2	99.0
	WHT	44.6	93.6	101.0
	ORG	83.3	96.0	104.0
	YEL	DO NOT USE	-	-

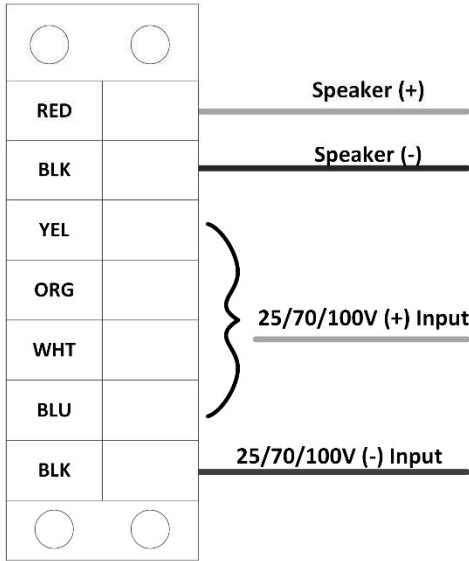

**INDOOR AND OUTDOOR DAMP
INSTALLATION INSTRUCTIONS: 90243A-MAN-LINEWAVE
MAX VOLTAGE: 100VRMS
MAX SUPERVISORY VOLTAGE: 32VDC**

15224A-1 REV D

3.5. 72542B-802 - Power Draw and Output SPL

Model Number	Input Voltage RMS	Tap Color	Power Draw, Watts	dB SPL Max 1M, A-Weighted	* dB SPL Reverb @ 10ft	* dB SPL Anechoic @ 3m
90243A-804	25V	Blue	3.2	106	83.3	92.1
	25V	White	6.3	109	86.3	95.1
	25V	Orange	12.9	111	89.3	97.4
	25V	Yellow	24.3	114	91.7	100.0
	70V	Blue	24.3	115	91.8	101.0
	70V	White	46.6	118	94.4	103.0
	70V	Orange	90.6	120	96.8	105.0
	70V	Yellow	159.3	123	98.4	106.0
	100V	Blue	47.8	118	94.5	103.0
	100V	White	89.1	121	96.8	105.0
	100V	Orange	165.8	123	98.7	107.0

*UL Standard SPL Measurement

3.6. 72542B-802 Transformer Wiring Guide – Used for 90243A-804

TRANSFORMER MODULE



SIGNALING
UL
LISTED

TYPE F SUBASSEMBLY
S35565

ISSUE DATE: 12/16/2019

72542B-802-L High Power Transformer
Secure Speaker (+), Speaker (-), and Input (-) as shown.
Secure 25/70/100V (+) Input to desired power setting.
Table assumes 90243A-804 load.

Input Power Requirements				
Input (VRMS)	Tap Color	Power (W) 90243A-804	UL 1480 SPL @ 10ft 90243A-804	ULC S541 SPL @ 3m 90243A-804
25	BLU	3.2	83.3	92.1
	WHT	6.3	86.3	95.1
	ORG	12.9	89.3	97.4
	YEL	24.3	91.7	100.0
70	BLU	24.3	91.8	101.0
	WHT	46.6	94.4	103.0
	ORG	90.6	96.8	105.0
	YEL	159.3	98.4	106.0
100	BLU	47.8	94.5	103.0
	WHT	89.1	96.8	105.0
	ORG	165.8	98.7	107.0
	YEL	DO NOT USE	-	-

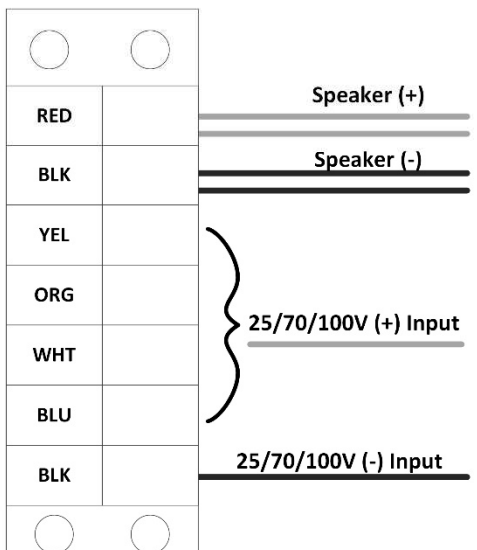

INDOOR AND OUTDOOR DAMP
INSTALLATION INSTRUCTIONS: 90243A-MAN-LINEWAVE
MAX VOLTAGE: 100VRMS
MAX SUPERVISORY VOLTAGE: 32VDC

15224A-2 REV D

4. Warranty

Ultra Electronics – USSI warrants that its products shall conform to the published specifications as of the date of order and shall be free from defects in material and workmanship.

Upon receipt of the returned product(s), Ultra Electronics – USSI will repair or replace any and all product(s) at its discretion. Ultra Electronics – USSI will not issue a credit for product(s) returned through the Return Authorization process. This warranty is extended to the original purchaser and all subsequent owners, provided a copy of the original dated bill of sale is presented when service is requested under warranty.

HyperSpike® Warranty Period

Such warranty shall extend for a period of one (1) year from the date of shipment from USSI's facility.

How to Obtain Service Under This Warranty

If your product(s) should require service, please write, phone, fax, or email us at:

Ultra Electronics – USSI
4868 East Park 30 Drive
Columbia City, Indiana, USA 46725
PH: 260-248-3665
Email: ServiceDepartment@ultra-ussi.com

Ultra Electronics – USSI will provide a Return Material Authorization (RMA) number so that you can ship the product(s) to our factory. Do not ship the product(s) to us without first obtaining an RMA number. Place the RMA number on all boxes returned to the factory. You are responsible for transporting your product(s) to our factory. We will pay the return shipping charges on all product(s) repaired under warranty.

Failures Not Covered by This Warranty

This warranty covers defects in manufacture only. It does not cover:

- 1) damage caused by accident, misuse, abuse, product modification, or neglect;
- 2) damage incurred during shipment (you must claim these damages from the carrier);
- 3) damage resulting from failure to operate the product in accordance with the instruction manual; or
- 4) damage resulting from attempted repairs by unauthorized personnel.

Exclusion of Certain Damages

Ultra Electronics – USSI's liability is limited to the repair or replacement, at our option, of any defective product(s) and shall in no event include indirect, consequential, incidental, punitive, or special commercial damages of any kind. Some states do not allow the exclusion or limitation of indirect, consequential, incidental, punitive, or special damages so the preceding limitation or exclusion may not apply to you.

Warranty After Repairs

An additional warranty of ninety (90) days will be extended to any parts that were repaired or replaced. The original standard warranty or any extended warranty that was purchased at the original time of sale of the product(s) is still in effect for the remainder of the warranty term.



Ultra Electronics – USSI
4868 East Park 30 Drive
Columbia City, IN 46725 USA
+1-260-248-3666